

G-Series Cooler

Instruction Manual

RCM TEQ²

Models: Listed on Inside Cover



U.S. PATENT No. 8,215,125



G-Series Cooler Instruction Manual

RCM TEQ² Models:
RCM TEQ2-N23NB

RCM TEQ²

Table of Contents

Parts & Identification List..... 4

Safety Instructions..... 5

Installation..... 6

 Ambient Environment..... 6

 Preparation Prior to Operation 6

 Electrical Requirements 6

Installation & Operation 7

Rechargeable Battery Instructions 7

Beverage Storage..... 7

Maintenance 8

Graphic Replacement 8

Specifications 9

Flammable Refrigerant Warnings 9

Troubleshooting..... 10

Circuit Diagrams 11

For Future Reference

- This easy-to-use manual will guide you in getting the best use of your cooler.
- Remember to record the model number and the serial number. This information can be found on the inside of your cooler.
- Keep your receipt with this manual for future warranty service.

Model #: _____

Serial #: _____

Date of Purchase: _____



PARTS & IDENTIFICATION

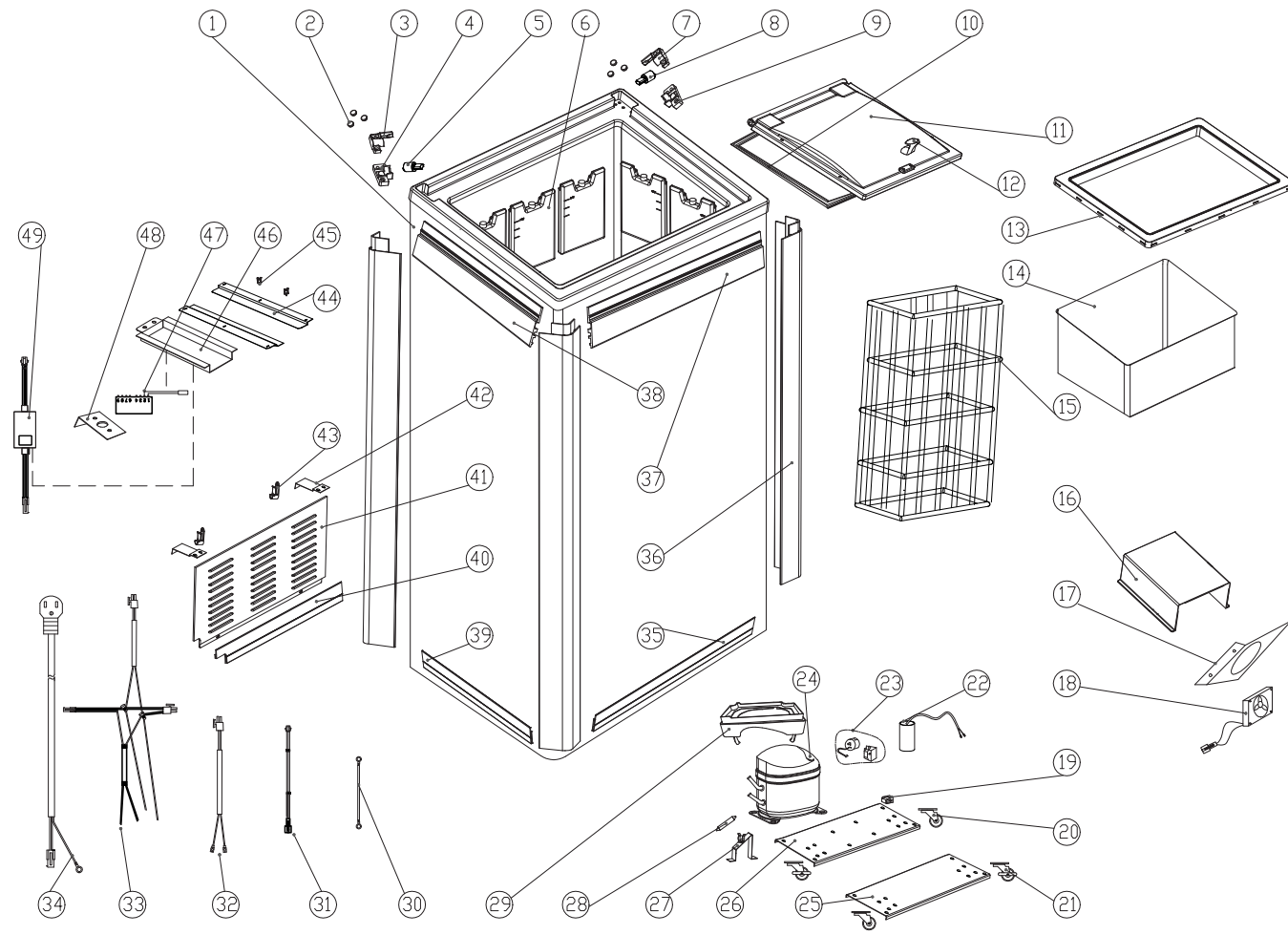

- | | | | |
|------------------------------|--|--------------------------------------|-------------------------------|
| 1. Cooler Cabinet | 14. Inner Liner | 27. Holder Assembly for Filter Drier | 40. Bottom Back Graphic Strip |
| 2. Hinge Cover Cap (6) | 15. Basket | 28. Filter Drier | 41. Compressor Room Cover |
| 3. Dampener Box Left Upper | 16. Baffle of Evaporator Fan | 29. Drip Pan | 42. Cover Supporter (2) |
| 4. Dampener Box Left Bottom | 17. Evaporator Fan Support | 30. Ground Wire | 43. Power Cord Holder (2) |
| 5. Dampener Left | 18. Evaporator Fan | 31. Fan Connecting Wire | 44. Rail Supporter (2) |
| 6. Coolant Box (30) | 19. Line Retaining Clip | 32. Compressor Connecting Wire | 45. Wire Retaining Clip (4) |
| 7. Dampener Box Right Upper | 20. Caster (2) | 33. Thermostat Connecting Wire | 46. Fixing Plate |
| 8. Dampener Right | 21. Caster with Lock (2) | 34. Power Cord | 47. Thermostat |
| 9. Dampener Box Right Bottom | 22. Capacitor | 35. Bottom Front Graphic Strip | 48. Thermostat Bracket |
| 10. Door Gasket | 23. Overload Protector & Starter Relay | 36. Corner Graphic Strips (4) | 49. Transformer |
| 11. Lid Assembly | 24. Compressor | 37. Top Magnet Strips Front/Back (2) | |
| 12. Handle | 25. Front Bottom Baffle | 38. Top magnet Strips Sides (2) | |
| 13. Rim | 26. Compressor Base | 39. Bottom Side Graphic Strip (2) | |

SAFETY INSTRUCTIONS

- When using this appliance, always follow the basic safety precautions:
- Read the entire User's Manual before operating this appliance.
- Use this appliance only for its intended purpose as described in this User's Manual.
- This cooler must be properly installed in accordance with the installation instructions before being used. See grounding instructions.
- IDW requires that a dedicated circuit be used for the unit. Failure to do so voids warranty.
- Never unplug your cooler by pulling on the power cord. Always grasp the plug firmly and pull it straight out from the outlet.
- Unplug your cooler before cleaning or making any repairs.
Note: If for any reason this product requires service, we strongly recommend that a certified technician perform the service.
- When disconnecting the power source, wait at least 5 minutes to reconnect the power to avoid damage to the compressor and the cooling system.
- Immediately repair or replace all electrical cords that have become frayed or otherwise damaged. Do not use a cord that shows cracks or abrasion damage along its length, the plug or the connector end.
- Do not operate or store your cooler near or around explosive fumes, gasoline or other flammable vapors and liquids.
- Do not use flammable liquids to clean unit.
- Setting the temperature control to the 0 position does not remove power to the light circuit, perimeter heaters, or evaporator fans.
- The temperature control is factory set for maximum performance.
- To avoid damage to the casters, do not transport the cooler on rough surfaces.
- The battery may release poisonous gas or explode if it is burned, broken or if air flow is restricted.
- Do not remove the battery cover.

- Do not touch the battery after the cooler has been plugged in to avoid electric shock.

PLEASE SAVE THESE INSTRUCTIONS!

DANGER!

PROPER DISPOSAL OF THE REFRIGERATOR

Pre-Caution, Non-Operating Coolers Should Have:

- Lid removed.
- Baskets kept in place in order to prevent any small child from climbing inside cooler.

For Proper Disposal of Cooler: Distributors/retailers need to contact a qualified service technician:

- To recover all refrigerant from the cooler
- To remove the compressor or remove the oil from the compressor

Then the distributor/retailer can contact their local metal recycling center to pick up the remaining cabinet, shelves, etc. By law, disposal of hazardous wastes may be subject to fines and imprisonment under the provisions of the environmental regulations. For more information please visit: <http://www.epa.gov/osw/hazard/index.htm>



INSTALLATION

Installation of the cooler must be done according to applicable local codes or equivalent.

Ambient Environment

- Place cooler on an even surface to reduce vibration and noise.
- To transport, do not tilt the cooler beyond a 45 degree angle.
- Do not place cooler in direct sunlight or near any heat sources.
- Do not place cooler in environment temperatures that exceed 80°F.
- Do not place cooler in below normal temperatures.
- Do not place cooler in extreme humid environments, this may cause components to rust.
- Do not place cooler near constant running or splattering water, this may cause immediate damage to refrigeration system.
- Must allow at least 4" between rear of cooler and wall for proper ventilation and heat dissipation of cooler.
- Do not place furniture or other articles with sharp edges near the cooler in order to prevent damage to the glass door.
- This cooler is for indoor use.
- Place unit in it's final location, making certain there is adequate ventilation in the room.

WARNING: Warranty is void if ventilation is insufficient.

Preparation Prior to Operation

- Remove all packaging materials before using cooler. This includes: foam pedestal, adhesive tape (used to fix accessories) and protective gaskets.
- Inspect cooler for concealed damage. Immediately file a claim with the freight carrier if there is damage. IDW is not responsible for damage incurred during shipping.
- Cooler must remain unplugged in an upright position for 1 hour prior to use.
- Clean the interior surface with a soft cloth and lukewarm water before operation.
- Ensure that drain hose or hoses are positioned in the pan.
- Remove plug and cord from inside the lower rear of the cooler.
- The unit should be placed close enough to the electrical supply so that extension cords are not used.

Electrical Requirements

- This model operates with a 110-120V/60Hz power supply. Check the electrical outlet for proper voltage.
- Dedicate one outlet for the use of the cooler.
- Do not use an extension cord or any other multiple connectors as this can lead to compressor failure.
- If the cord is damaged, it must be replaced.
- For your safety, plug the unit into a grounded wall outlet. Please check with a certified electrician for details.

WARNING: Do not use extension cords.
WARNING: Compressor warranties are void if compressor burns out due to low voltage.
WARNING: Power cord ground pin must NOT be removed!

INSTALLATION AND OPERATION

1. Connect the empty RCM to a Power Source for 24 hours.
2. After the empty cooler has been operating for an initial period of 24 hours, the unit can then be loaded with products*.
3. The cooler can then be unplugged and rolled to any high traffic retail location for up to 10 hours. After 10 hours the unit must be plugged in again for an additional 24 hours. (The Re-Charge cycle)

It is important to understand that the Re-Charge Cold Merchandiser (RCM) is designed to operate differently than typical beverage coolers. Typical coolers circulate the cold the air inside the cabinet to chill the beverages. The RCM does not follow this principle. The RCM freezes liquid filled coolant packs within the interior walls of the cabinet. It is important that these coolant packs are completely frozen to ensure that the beverages will be kept at a cold temperature for the maximum amount of time while the unit is unplugged and moved to the desired location. The initial time required to freeze these coolant packs can be between 12 and 24 hours depending on the operating environment.

*For best results, on initial set-up we recommend the RCM is allowed 24 hours to completely freeze the coolant packs. Following this initial 24 hour "charge" the subsequent "recharge" time will be much less. By following this extended initial freezing period, you will be ensuring that consumers are receiving the coldest possible beverage for the best possible extended time while the RCM is unplugged.

RECHARGEABLE BATTERY INSTRUCTIONS

The RCM features a rechargeable battery that powers the inner fan.

1. Upon first using the cooler, or when the cooler has not been operated for a long period of time, it will take 12-18 hours for the battery to charge.
2. The RCM battery is a size N.
3. If the RCM is left plugged in for longer than 48 hours, it will reduce the lifetime of the rechargeable battery.

BEVERAGE STORAGE

- Leave adequate space between beverage cans to allow air circulation
- This cooler is primarily for storing beverage cans and plastic bottles. Avoid putting glass containers in this cooler.
- All beverage products should be properly sealed to avoid leaking into the cooler.

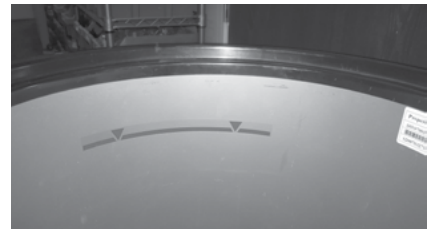

MAINTENANCE

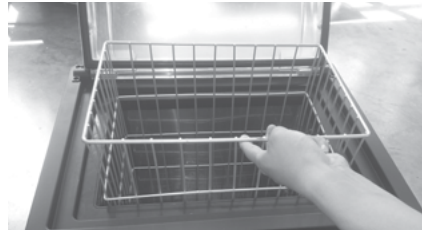

1. Remove the basket from the inside of the cooler.

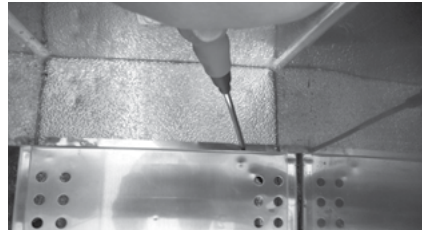

2. Using a Phillips screwdriver, unscrew the (4) screws at the base of the cooler to remove the baffler.

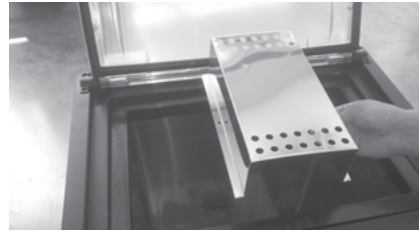

3. Remove the inner fan cover.
4. Service or change inner fan.
5. Reverse steps 1-4 after maintenance.

Accessing Cooler Compartment:



1. Using a Phillips screwdriver, unscrew the (2) screws at the base of grill.



2. Remove the grill.



3. Replace or service the parts in the compressor compartment.
4. Reverse steps 1-4 after maintenance.

GRAPHIC REPLACEMENT



1. Place graphic against the face of the cooler and open the top magnetic strip.



2. Wedge the graphic under the plastic frame of the cooler (sides and bottom) and release the magnetic strip over the top of the graphic.



3. Adjust the graphic to the correct position.

SPECIFICATIONS

MODEL	VOLUME(L)	RATED VOLTAGE	RATED CURRENT	REFRIGERANT
RCM TEQ2-N23NB	2.3ft ³	110-120V/60Hz	1.5A	R600a
NSF/ANSI-7: Beverage Cooler		A refrigerator intended solely for the storage and/or display of packaged beverage products that are non-potentially hazardous, such as soda (pop), beer, and wine.		



CAUTION FLAMMABLE REFRIGERANT

- **DANGER - Risk Of Fire Or Explosion.** Flammable Refrigerant Used. To Be Repaired Only By Trained Service Personnel. Do Not Puncture Refrigerant Tubing.
- **CAUTION - Risk Of Fire Or Explosion.** Flammable Refrigerant Used. Consult Repair Manual/Owner's Guide Before Attempting To Install or Service This Product. All Safety Precautions Must be Followed.
- **CAUTION - Risk Of Fire Or Explosion.** Dispose Of Properly In Accordance With Federal Or Local Regulations. Flammable Refrigerant Used.
- **CAUTION - Risk Of Fire Or Explosion** Due To Puncture Of Refrigerant Tubing; Follow Handling Instructions Carefully. Flammable Refrigerant Used.
- **CAREFUL** - Handling, moving and operating of the refrigerator or freezer to avoid either damaging the refrigerant tubing, or increasing the risk of a leak.
- **CAUTION** - Component parts shall be replaced with like components and that servicing shall be done by factory authorized service personnel, so as to minimize the risk of possible ignition due to incorrect parts or improper service.

TROUBLESHOOTING

The following are NOT malfunctions:

Situation	Causes
Liquid flowing noise within cooler	<ul style="list-style-type: none"> This is the sound of the cooling agent flowing through the pipes.
Refrigeration system is shutdown for longer periods of time while temperature inside is still very low	<ul style="list-style-type: none"> This refrigerator is well insulated and can maintain a relatively ambient temperature.
Condensation on door/lid	<ul style="list-style-type: none"> This may be due to a high indoor humidity or the cooler's temperature is set too low. Wipe the door dry with a towel.

- 1 This refrigerator has been designed and manufactured according to National standards. If there are any questions during use, refer to this operation manual to help troubleshoot problems.
- 2 When disposing of the cooler, please remove the door/lid and lock assembly to avoid children accidentally becoming trapped inside the cooler.

Prior to calling service, check the following:

Issues	Solutions
Cooler is not working properly	Please check power supply: <ul style="list-style-type: none"> Check the electrical outlet for power, and that the plug is properly inserted. Check to see if the circuit breaker is tripped or the fuse is blown. Check if the condenser is free of dirt and debris. Check for low voltage
Cooler is not keeping product cool	<ul style="list-style-type: none"> Provide ample space between all products to ensure proper circulation of air. Keep unit away from direct sunlight or other heating source. Keep the door closed as often as possible. Be certain the cooler is not touching external objects or walls.
Excessive noise	<ul style="list-style-type: none"> Be certain the cooler is placed on a level surface. Be certain the cooler is not touching external objects or walls.
Compressor turns on and off frequently	<ul style="list-style-type: none"> The room temperature is higher than normal. The door is not closed completely. The door gasket is not sealed properly. There is insufficient clearance around the cooler. The thermostat is not set properly. The frequency of cycling will be reduced when all of the product reaches the set temperature.

AFTER SALES SERVICE

Any product has the possibility of malfunction. Please observe the cooler's operation and any changes to product being stored. If there are any abnormal cases, refer to the table below. If there is still no change after following the below instructions, please inform our service center in a timely manner to avoid a further loss of the unit.

Information to provide to your qualified service professional:

- Serial number from the interior wall of the cooler
- Coolers' installation address and contact information
- Installation location hours and operation
- Nature of problem
- Any reports of power interruptions
- Recent service or maintenance completed on the cooler
- Has the cooler been relocated from original installation location
- Clear access to the cooler
- Coolers' instruction manual

CIRCUIT DIAGRAM

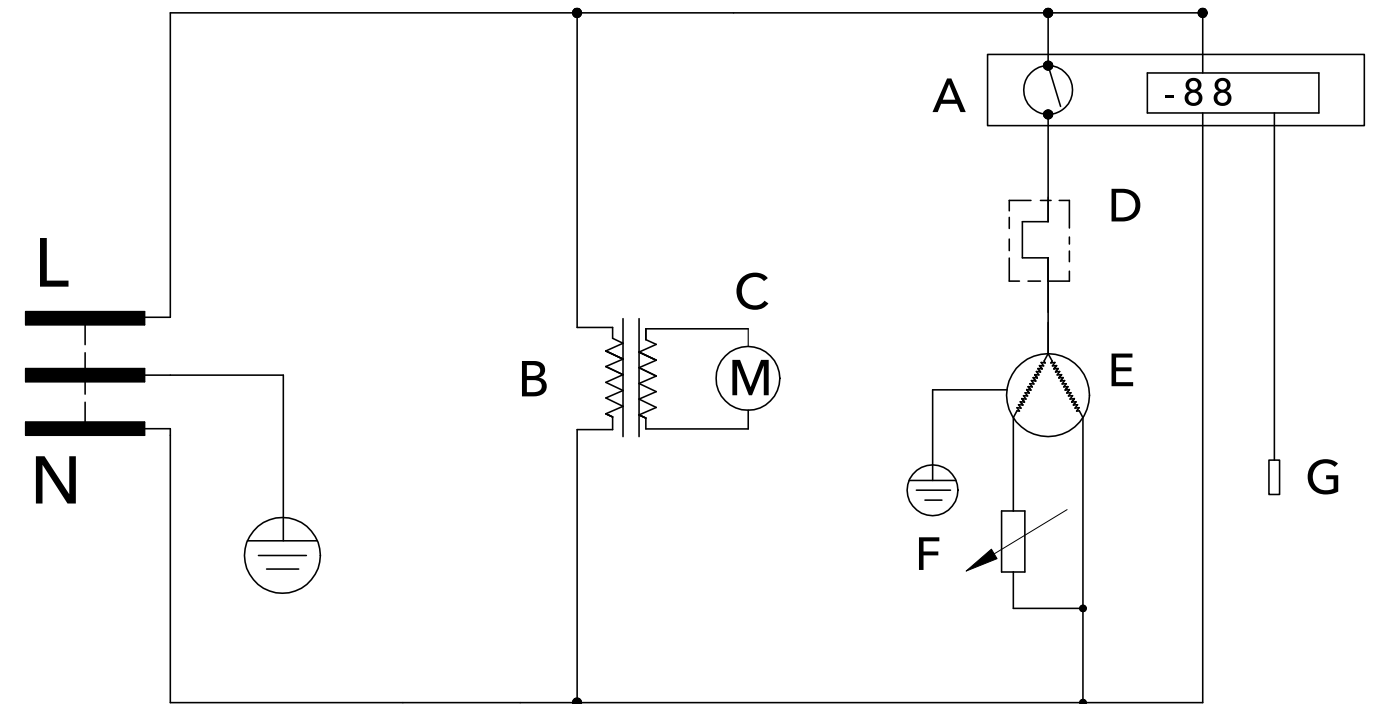

- A. Thermostat
- B. Transformer
- C. Evaporator Fan
- D. Overload Protector
- E. Compressor
- F. Starting Relay
- G. Temperature Probe



Innovative DisplayWorks, Inc.
8825 Boston Place, Rancho Cucamonga CA 91730
To locate the distributor in your area go to: <http://www.idw.global/contact/#distributors>