

G1.5

COUNTERTOP COOLER

G-Series Coolers

FEATURES

- Exterior Dimensions (WDH): 14.5" x 15.875" x 21.5"
- Internal Volume: 0.96 ft³
- Dynamic LED Lighting In Door Provides Enhanced Product Illumination While Greatly Reducing Energy Consumption
- Forced Air Evaporator System For Fast Product Temperature Pull Down
- High Impact Side Panel Graphics
- High Density Environmentally Friendly Insulation
- Utilizes Climate-Friendly Natural Refrigerant
- 1 Fixed Powder-Coated Metal Shelf
- Double-paned, Low "E", Self-Closing Glass Door
- LED Interior Lighting
- Durable Pre-painted Steel Cabinet and Heavy Duty Inner Liner
- Adjustable Temperature Control
- 9' Heavy Duty Power Cord

CERTIFICATIONS

110v

- UL471
- NSF/ANSI-7: Type 2 Display Refrigerator
- ENERGY STAR® Qualified



G1.5

COUNTERTOP COOLER

G-Series Coolers

TECH SPECS

Refrigerant	R600a
Amps	2
Volts/Hz	110-120V/60Hz
Compressor HP	1/8

SHIPPING SPECS

Gross Weight	57 lbs
Net Weight	53 lbs
Carton Dims (WDH)	16.5"x18.5"x22.5"
Units per Pallet	18
Shipping Options:	
Floor Loaded	20' ~ 240 40'HQ ~ 500 53' ~ 468

DIMENSIONS

Exterior: 14.5"W x 15.875"D x 21.5"H

Interior: 11.375"W x 9.5"D x 16.875"H

Shelf: 10.875"W x 8.25"D

Internal Volume: 0.96 ft³



EXTERIOR DIMENSIONS

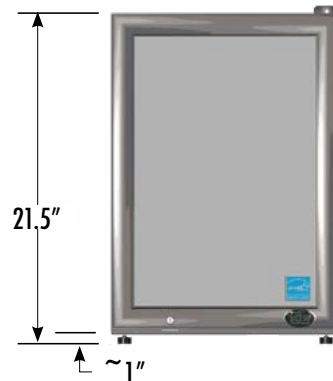

INTERIOR DIMENSIONS

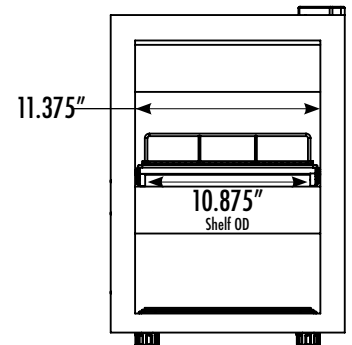

PACKOUT CAPACITIES

		Facings	Deep	Total Capacity	Total Rows
	1 Shelf	4	x 3	= 20	2
	Base	4	x 2		
	1 Shelf	4	x 3	= 20	2
	Base	4	x 2		

