

G-3

COUNTERTOP COOLER

G-Series Coolers

FEATURES

- Exterior Dimensions (WDH): 18.25" x 20.25" x 34.75"
- Internal Volume: 3.48 ft³
- Dynamic LED Lighting In Door Provides Enhanced Product Illumination While Greatly Reducing Energy Consumption
- Forced Air Refrigeration System For Fast Product Temperature Pull Down
- High Impact Side Panel Graphics
- High Density Environmentally Friendly Insulation
- Utilizes Climate-Friendly Natural Refrigerant
- 2 Adjustable Powder-Coated Metal Shelves
- Double-Paned, Low "E", Self-Closing Glass Door
- LED Interior Lighting
- Durable Pre-Painted Steel Cabinet and Heavy Duty Inner Liner
- Adjustable Temperature Control
- 9' Heavy Duty Power Cord

CERTIFICATIONS

110v

- UL471
- NSF-7, Type 2 Display Refrigerator
- ENERGY STAR[®] Qualified



G-3

COUNTERTOP COOLER

G-Series Coolers

TECH SPECS

Refrigerant	R600a
Amps	.78A
Volts/Hz	110-120V/60Hz
Compressor HP	1/6

SHIPPING SPECS

Gross Weight	102 lbs
Net Weight	93 lbs
Carton Dims (WDH)	20"x22.5"x37.25"
Units per Pallet	8
Shipping Options:	
Floor Loaded	20' ~ 88
	40'HQ ~ 184
	53' ~ 208

DIMENSIONS

Exterior: 18.25"W x 20.25"D x 34.75"H



Interior: 15"W x 11.625"D x 30.5"H

Upper Shelf: 14.25"W x 11"D

Lower Shelf: 14.25"W x 9.75"D

Internal Volume: 3.48ft³

PACKOUT CAPACITIES

	Shelves	Facings	Deep	Total Capacity	Total Rows
	3 Shelves	5 x 4		= 75*	4
	Base	5 x 3			
	3 Shelves	5 x 4		= 75*	4
	Base	5 x 3			
	2 Shelves	5 x 4		= 55**	3
	Base	5 x 3			

* Additional shelves, beyond what is supplied with the cooler, may be required to achieve this maximum pack-out.
 ** 20oz pack-outs may vary depending on package size.



EXTERIOR DIMENSIONS

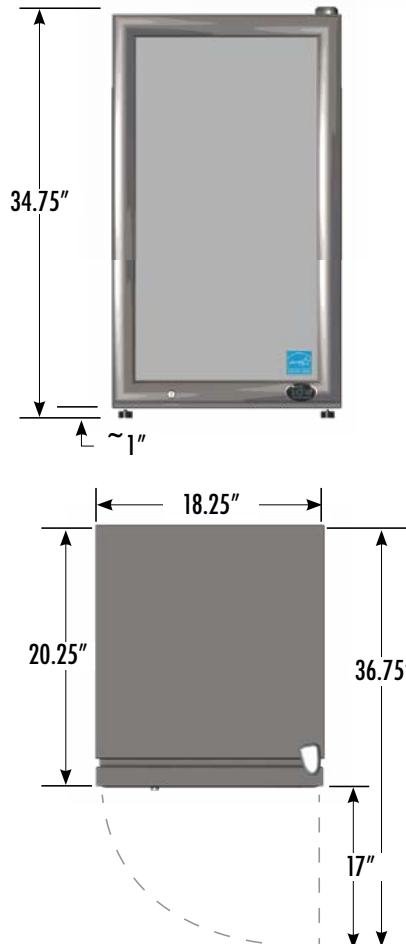

INTERIOR DIMENSIONS

