

G-Series Cooler

RCM-2

RECHARGE COLD MERCHANDISER



****PATENT PENDING****



RCM²
RECHARGE COLD
MERCHANDISER

**Manual is for the
following models:
RCM-2-N13EB**



Instruction Manual

**Manual is for the
following models:
RCM-2-N13EB**

Instruction Manual



FOR YOUR FUTURE REFERENCE

- This easy-to-use manual will guide you in getting the best use of your cooler.
- Remember to record the model number and the serial number. This information can be found on the inside of your cooler.
- Keep your receipt with this manual for future warranty service.

Model #: _____

Serial #: _____

Date of Purchase: _____

TABLE OF CONTENTS

Parts and Identification	2
Safety Instructions.....	3
Preparation.....	4
Location	5
Installation and Operation.....	5
Rechargeable Battery Instructions.....	5
Beverage Storage.....	6
Maintenance	6
Changing Graphics.....	7
Troubleshooting	8
Cleaning	8
Circuit Diagram.....	10

PARTS AND IDENTIFICATION

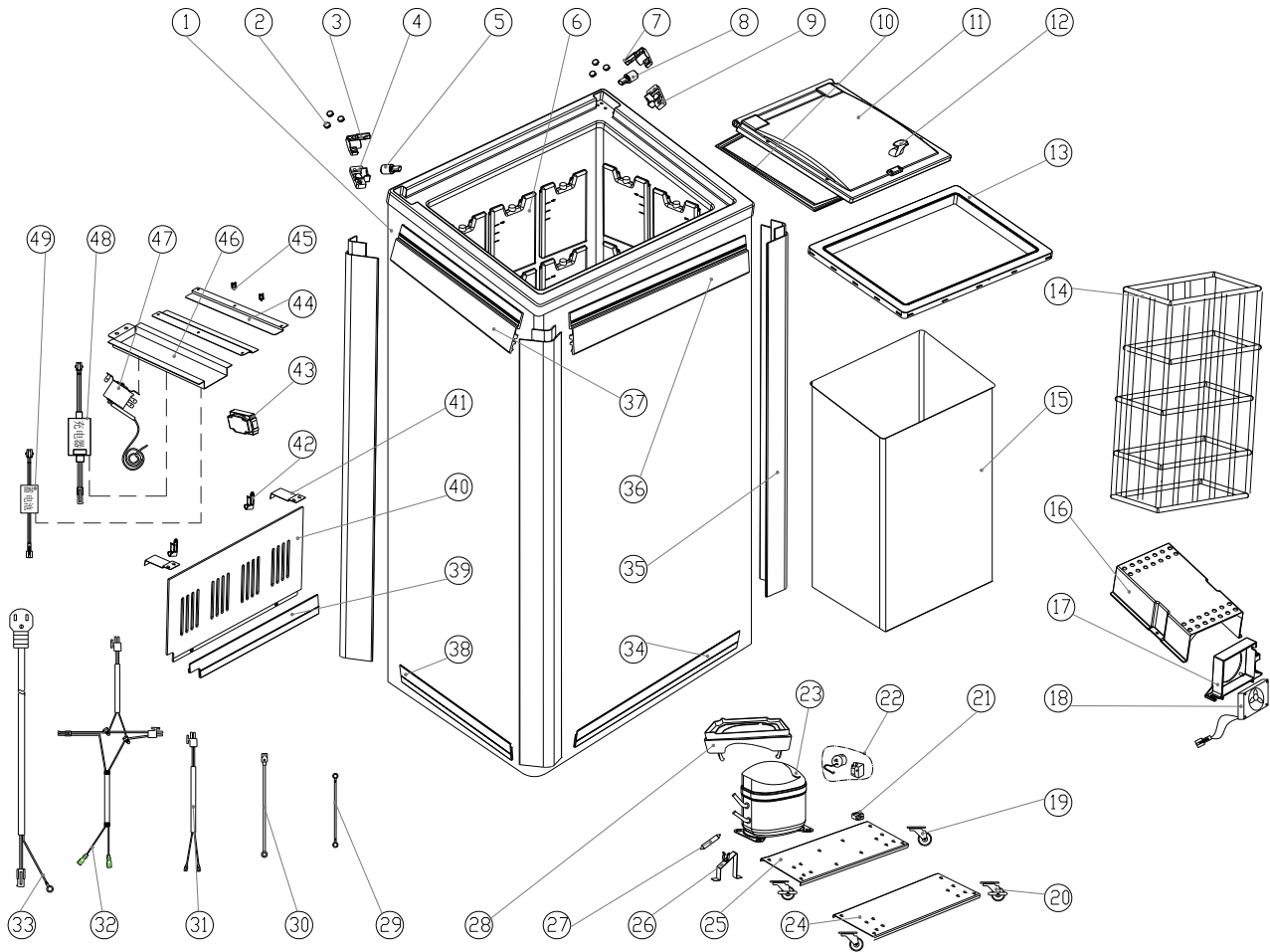

- | | | | |
|-------------------------------|-----------------------------------|--------------------------------------|-------------------------------------|
| 1. Cabinet | 14. Basket | 27. Dryer Filter | 40. Compressor Room Cover |
| 2. Hinge Cover (6) | 15. Cooling Inner | 28. Drip Pan /Cover | 41. Cover Supporter |
| 3. Damping Box (left upper) | 16. Baffle of Inner Fan | 29. Ground Wire -1 | 42. Power Cord Holder |
| 4. Damping Box (left bottom) | 17. Inner Fan Supporter | 30. Ground Wire -2 | 43. Battery Box |
| 5. Damping (left) | 18. Evaporator Fan | 31. Compressor Connection Wire | 44. Rail Supporter |
| 6. Coolant Box (30) | 19. Castor (universal) (2) | 32. Thermostat Connection Wire | 45. Wires Retaining Clip |
| 7. Damping Box (right upper) | 20. Castor (universal, brake) (2) | 33. Power Cord | 46. Fixing Plate |
| 8. Damping (right) | 21. Retaining Clip of Line | 34. Bottom Plastic Strip (front) | 47. Constant Temperature Thermostat |
| 9. Damping Box (right bottom) | 22. Compressor Accessories | 35. Plastic Strips for Side Graphics | 48. Recharger |
| 10. Door Gasket | 23. Compressor | 36. Magnet Strips (front/back) | 49. Battery |
| 11. Lid | 24. Front Bottom Baffle | 37. Magnet Strips (sides) | |
| 12. Handle | 25. Compressor Base | 38. Bottom Plastic Strip (sides) | |
| 13. Rim | 26. Dryer Filter Supporter | 39. Bottom Plastic Strip (back) | |

SAFETY INSTRUCTIONS

When using this appliance, always follow the basic safety precautions:

1. Read the entire User's Manual before operating this appliance.
2. Use this appliance only for its intended purpose as described in this User's Manual.
3. This cooler must be properly installed in accordance with the installation instructions before being used. See grounding instructions.
4. IDW requires that a dedicated circuit be used for the unit. Failure to do so voids warranty.
5. Never unplug your cooler by pulling on the power cord. Always grasp the plug firmly and pull it straight out from the outlet.
6. Unplug your cooler before cleaning or making any repairs.
Note: If for any reason this product requires service, we strongly recommend that a certified technician perform the service.
7. When disconnecting the power source, wait at least 5 minutes to reconnect the power to avoid damage to the compressor and the cooling system.
8. Immediately repair or replace all electrical cords that have become frayed or otherwise damaged. Do not use a cord that shows cracks or abrasion damage along its length, the plug or the connector end.
9. Do not operate or store your cooler near or around explosive fumes, gasoline or other flammable vapors and liquids.
10. Do not use flammable liquids to clean unit.
11. Setting the temperature control to the 0 position does not remove power to the light circuit, perimeter heaters, or evaporator fans.
12. Do not adjust the temperature control. The temperature control is factory set between levels 4 and 5 for maximum performance.

IMPORTANT!
Please Save These Instructions
For Proper Disposal of the Refrigerator!

PRE-CAUTION, NON-OPERATING COOLERS SHOULD HAVE:

1. Door removed
2. Shelves kept in place in order to prevent any small child from climbing inside cooler

FOR PROPER DISPOSAL OF COOLER: Distributors / retailers need to contact a qualified service technician:

1. To recover all refrigerant from the cooler
2. To remove the compressor or remove the oil from the compressor

Then the distributor / retailer can contact their local metal recycling center to pick up the remaining cabinet, shelves, etc. By law, disposal of hazardous wastes may be subject to fines and imprisonment under the provisions of the environmental regulations. For more information please visit: <http://www.epa.gov/osw/hazard/index.htm>

INSTALLATION

Installation of the cooler must be done according to applicable local codes or equivalent.

Ambient Environment

- Place cooler on an even surface to reduce vibration and noise.
- To transport, do not tilt the cooler beyond a 45 degree angle.
- Do not place cooler in direct sunlight or near any heat sources.
- Do not place cooler in environment temperatures that exceed 109°F.
- Do not place cooler in below normal temperatures.
- Do not place cooler in extreme humid environments, this may cause components to rust.
- Do not place cooler near constant running or splattering water, this may cause immediate damage to refrigeration system.
- Must allow at least 4" between rear of cooler and wall for proper ventilation and heat dissipation of cooler.
- Do not place furniture or other articles with sharp edges near the cooler in order to prevent damage to the glass door.
- This cooler is for indoor use.
- Place unit in it's final location, making certain there is adequate ventilation in the room.

WARNING: Warranty is void if ventilation is insufficient.

PREPARATION PRIOR TO OPERATION

Unpacking

- Remove all packaging materials before using cooler. This includes: foam pedestal, adhesive tape (used to fix accessories) and protective gaskets.
- Inspect cooler for concealed damage. Immediately file a claim with the freight carrier if there is damage. IDW is not responsible for damage incurred during shipping.
- Cooler must remain unplugged in an upright position for 1 hour prior to use.
- Clean the interior surface with a soft cloth and lukewarm water before operation.
- Ensure that drain hose or hoses are positioned in the pan.
- Remove plug and cord from inside the lower rear of the cooler.
- The unit should be placed close enough to the electrical supply so that extension cords are not used.

Electrical Requirements

- This model operates with a 110V/60Hz power supply. Check the electrical outlet for proper voltage.
- Dedicate one outlet for the use of the cooler.
- Do not use an extension cord or any other multiple connectors as this can lead to compressor failure.
- If the cord is damaged, it must be replaced.
- For your safety, plug the unit into a grounded wall outlet. Please check with a certified electrician for details.

WARNING: Do not use extension cords.

WARNING: Compressor warranties are void if compressor burns out due to low voltage.

WARNING: Power cord ground pin must NOT be removed!



LEVELING/LOCATION

- Place unit in a well-ventilated area. **WARNING: Warranty is void if ventilation is insufficient.**
- Unit must be leveled for proper operation, this will help prevent condensation.
- The cooler should be leveled front to back and side to side with a leveler.

INSTALLATION AND OPERATION

- 1 Connect the empty RCM² to a Power Source for 12+ hours.
- 2 After the empty cooler has been operating for an initial period of 12 hours, the unit can then be loaded with products*.
- 3 The cooler can then be unplugged and rolled to any high traffic retail location for up to 12 hours. After 12 hours the unit must be plugged in again for an additional 12 hours. (The Re-Charge cycle)

It is important to understand that the Re-Charge Cold Merchandiser (RCM²) is designed to operate differently than typical beverage coolers. Typical coolers circulate the cold the air inside the cabinet to chill the beverages. The RCM² does not follow this principle. The RCM² freezes liquid filled coolant packs within the interior walls of the cabinet. It is important that these coolant packs are completely frozen to ensure that the beverages will be kept at a cold temperature for the maximum amount of time while the unit is unplugged and moved to the desired location. The initial time required to freeze these coolant packs can be between 12 and 24 hours depending on the operating environment.

**For best results, on initial set-up we recommend the RCM² is allowed 24 hours to completely freeze the coolant packs. Following this initial 24 hour "charge" the subsequent "recharge" time will be much less. By following this extended initial freezing period, you will be ensuring that consumers are receiving the coldest possible beverage for the best possible extended time while the RCM² is unplugged.*

RECHARGEABLE BATTERY INSTRUCTIONS

The RCM² features a rechargeable battery that powers the inner fan.

- 1 Upon first using the cooler, or when the cooler has not been operated for a long period of time, it will take 12-18 hours for the battery to charge.
- 2 The RCM² battery is a size N.
- 3 If the RCM² is left plugged in for longer than 48 hours, it will reduce the lifetime of the rechargeable battery.

BEVERAGE STORAGE

1 Do not overload the cooler beyond the red limitation line.



2 Leave adequate space between beverage cans to allow air circulation.

3 This cooler is primarily for storing beverage cans and plastic bottles. Avoid putting glass containers in the cooler.

4 All beverage products should be properly sealed to avoid leaking into the cooler.

MAINTENANCE

Accessing Inner Fan:



1 Remove the basket from the inside of the cooler.

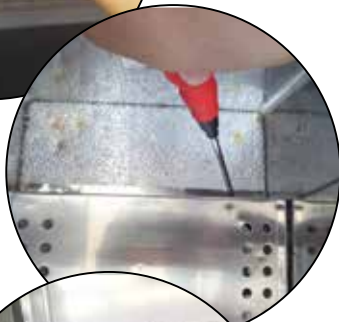

2. Using a Philips screwdriver, unscrew (4) screws at the cover of inner fan.



3 Remove the inner fan cover.

4 Service or change inner fan.

5 Reverse steps 1-4 after maintenance.

Accessing Compressor Compartment:



1 Using a Philips screwdriver, unscrew (2) screws at the bottom of grill.



2 Remove the grill



3 Replace or service the parts in the compressor compartment.

4 Reverse steps 1-3 after maintenance.

Changing Electric Impulse Cooler Graphics:



1 Place graphic against the face of the cooler, open the top magnetic strip.



2 Wedge the graphic under the plastic frame of the cooler (sides and bottom) and the magnetic strip.



3 Adjust the graphic to the correct position.

Troubleshooting

The following are NOT malfunctions:

Situation	Causes
Liquid flowing noise within cooler	<ul style="list-style-type: none"> This is the sound of the cooling agent flowing through the pipes.
Refrigeration system is shutdown for longer periods of time while temperature inside is still very low	<ul style="list-style-type: none"> This refrigerator is well insulated and can maintain a relatively ambient temperature.
Condensation on glass door	<ul style="list-style-type: none"> This may be due to a high indoor humidity or the coolers temperature is set too low. Wipe the door dry with a towel.

Prior to calling service, check the following:.

Issues	Solutions
Cooler is not working properly	<p>Please check power supply:</p> <ul style="list-style-type: none"> Check the electrical outlet for power, and that the plug is properly inserted. Check to see if the circuit breaker is tripped or the fuse is blown. Check if the condenser is free of dirt and debris. Check for low voltage
Cooler is not keeping product cool	<ul style="list-style-type: none"> Provide ample space between all products to ensure proper circulation of air. Keep unit away from direct sunlight or other heating source. Keep the door closed as often as possible. Be certain the cooler is not touching external objects or walls.
Excessive noise	<ul style="list-style-type: none"> Be certain the cooler is placed on a level surface. Be certain the cooler is not touching external objects or walls.
Compressor turns on and off frequently	<ul style="list-style-type: none"> The room temperature is higher than normal. The door is not closed completely. The door gasket is not sealed properly. There is insufficient clearance around the cooler. The thermostat is not set properly. The frequency of cycling will be reduced when all of the product reaches the set temperature.

After Sales Service

Information to provide to your qualified service professional:

- Serial number from the interior wall of the cooler;
- Coolers' installation address and contact information;
- Installation location hours and operation;
- Nature of problem;
- Any reports of power interruptions;
- Recent service or maintenance completed on the cooler;
- Has the cooler been relocated from original installation location;
- Clear access to the cooler;
- Coolers' instruction manual.

MAINTENANCE

Cleaning

- Unplug the cooler before cleaning.
- Use a soft cloth or sponge with water or soap (non-corrosive mild detergent). After cleaning, wipe the cooler using a dry cloth to prevent the cooler from rusting.
- Do not spray water on the cooler, and do not use hard or steel brushes to clean the cooler.
- Do not use organic solvents, boiling water, washing powders or acids while cleaning.

If the cooler will be in a non-operational state for a long period of time, clean as instructed above, and keep the door open until interior is dry.

MOVING THE COOLER

- Remove all product from the unit.
- Secure all loose parts inside the cooler.
- Tape the door shut.
- Ship the cooler in an upright position.

REFRIGERATION

- The RCM² Electric Impulse Cooler utilizes R134a refrigerant.

SPECIFICATIONS

Model:	RCM ² Electric Impulse Cooler
Power Supply (V/Hz):	220V/50Hz or 110V/60Hz
Dimension (WxDxH):	22" x 16.6" x 39.5"
Box Dimension (WxDxH):	24.25" x 19" x 43.7"

RCM² CIRCUIT DIAGRAM

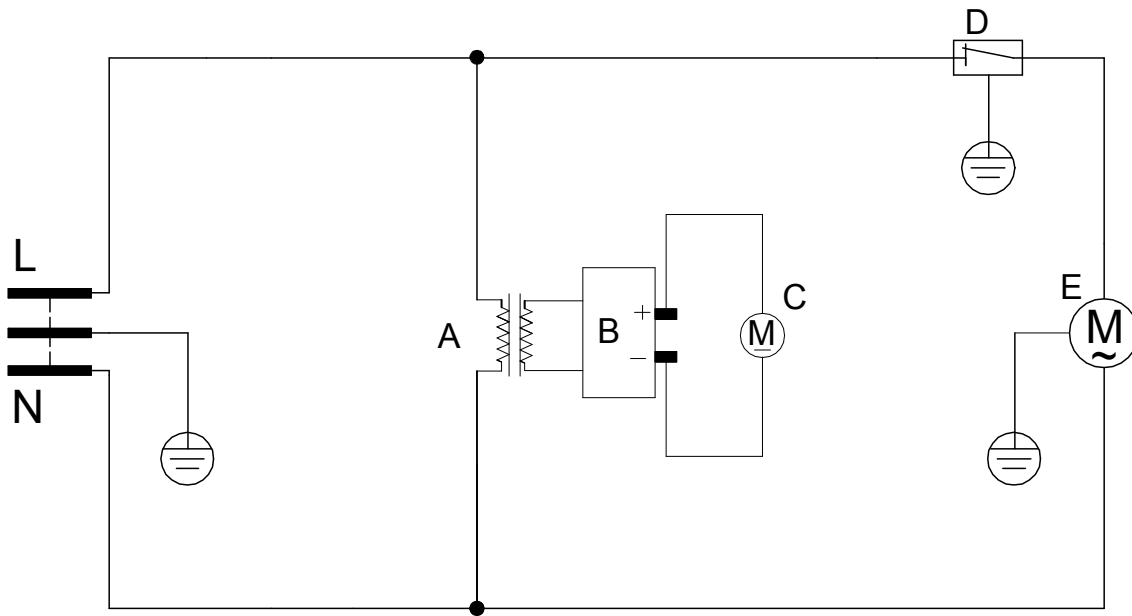

- A. Transformer
- B. Storage battery
- C. Evaporator fan
- D. Thermostat
- E. Compressor



Innovative DisplayWorks, Inc.

To locate the distributor in your area go to: <http://www.idw.global/contact/#distributors>