

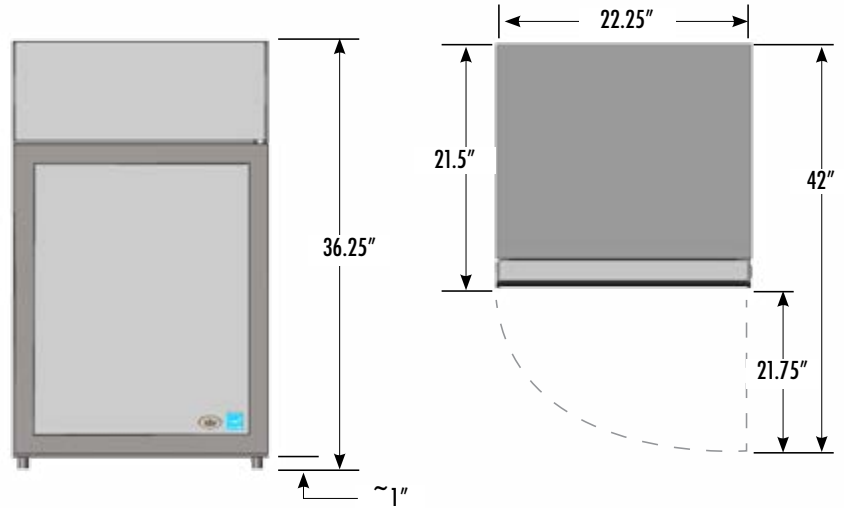

FEATURES

- Exterior Dimensions: 22.25"W x 21.5"D x 36.25"H
- Forced Air Evaporator System For Fast Product Temperature Pull Down
- High Density Environmentally Friendly Insulation
- High Impact Side Panel Graphics & LED Illuminated Canopy
- Double-Paneled, Self-Closing Glass Door With Lock
- Durable Pre-Painted Steel Cabinet & Heavy Duty Inner Liner
- 3 Fully Adjustable Powder-Coated Metal Shelves
- Adjustable Temperature Control
- LED Interior Lighting
- 9' Heavy Duty Power Cord
- Available in Climate-friendly Natural Refrigerant
- CETL & ETL Listed
- Conforms to NSF-7
- ENERGY STAR® Qualified





EXTERIOR DIMENSIONS (WDH) 22.25" x 21.5" x 36.25" inches
565 x 546 x 921 mm

SHELF DIMENSIONS (WD) 17.5" x 11.5" inches
445 x 292 mm

PACK-OUT CAPACITIES

	Facing	Depth	Shelves	Rows	Total Capacity
12OZ CAN	7	4	3	3	84
16OZ CAN	7	4	3	3	84
20OZ PET	6	4	2	2	48

TECH SPECS

	R134a	R600a
Refrigerant	R134a	R600a
Amps	2.8	2.8
Volts/Hz	110-120V/60Hz	110-120V/60Hz
Compressor HP	1/6	1/6

SHIPPING SPECS

Gross Weight	117 lbs/53 kg
Net Weight	104 lbs/47 kg
Carton Dims (WDH)	25.5"x23"x38.25"
Units per Pallet	8
Shipping Loads	40'HQ ~ 152 53' ~ 208

