

# GCG-26c

UPRIGHT COOLER



Manual is for the following models:

GCG-26-C14N7

GCG-26-C14NG

GCG-26-C14NI

GCG-26-C14NM

GCG-26-C14NJ

GCG-26

G-26-C14N7

G-26-C14NG

G-26-C14NI

G-26-C14NM

G-26-C14NJ

G-26



Manual is for the following models:

- GCG-26-C14N7
- GCG-26-C14NG
- GCG-26-C14NI
- GCG-26-C14NM
- GCG-26-C14NJ
- GCG-26
- G-26-C14N7
- G-26-C14NG
- G-26-C14NI
- G-26-C14NM
- G-26-C14NJ
- G-26

Instruction Manual

# GCG-26c

## FOR YOUR FUTURE REFERENCE

- This easy-to-use manual will guide you in getting the best use of your cooler.
- Remember to record the model number and the serial number. This information can be found on the inside of your cooler.
- Keep your receipt with this manual for future warranty service.

Model #: \_\_\_\_\_

Serial #: \_\_\_\_\_

Date of Purchase: \_\_\_\_\_

## TABLE OF CONTENTS

Parts & Identification .....	3
Safety Precautions .....	4
Features.....	5
Instructions .....	5
Ambient Environment.....	5
Preparation Before Operation.....	6
Replacing the Interior Light .....	7
Replacing the Door LED Lights .....	8
Replacing the Canopy Light .....	9
Startup, Operation & Temperature Adjustment.....	10
Lit Door 'Logo' Switch.....	10
Repair & Maintenance for Refrigeration Drawer.....	10
Condenser Maintenance .....	11
Maintenance .....	11
Cleaning Shutdown Questions & Answers.....	11
Canopy Graphics Replacement.....	12
Setting Up Power Cord Holder.....	12
Troubleshooting .....	13
After-Sales Service.....	13
GCG-26c Circuit Diagram .....	14
GCG-26c Electrical Wiring Diagram .....	15
G-26c Circuit Diagram .....	16
G-26c Electrical Wiring Diagram .....	17

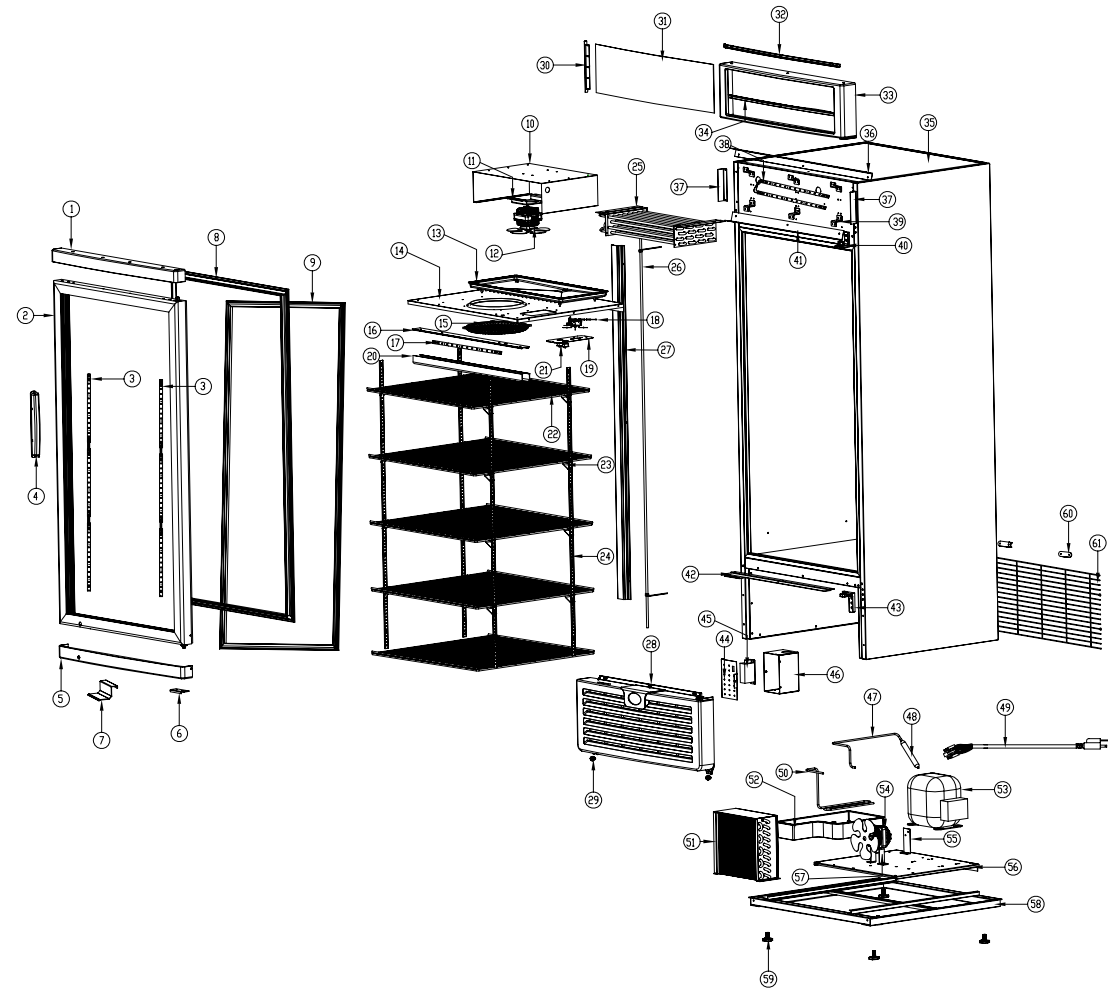

**PARTS & IDENTIFICATION**

- |                                    |  |   |
|------------------------------------|--|---|
| 1. Top Plastic Strip of Glass Door | 23. Fixation Clamp for Shelf               | 44. Electric Box Cover                  |
| 2. Glass Door                      | 24. Fixation Strip for Shelf               | 45. Switching Power Supply of LED Light |
| 3. LED Light in the Glass Door     | 25. Evaporator                             | 46. Electric Box                        |
| 4. Door Handle                     | 26. Return Pipe                            | 47. Connecting Tube for Dry Filter      |
| 5. Low Plastic Strip of Glass Door | 27. Return Pipe Cover                      | 48. Dry Filter                          |
| 6. Door Limiter                    | 28. Grill                                  | 49. Power Cord                          |
| 7. Door Support                    | 29. Plastic Fixation Column                | 50. Connecting Tube for Condenser       |
| 8. LED Light Cover                 | 30. Inserts                                | 51. Condenser                           |
| 9. Door Gasket                     | 31. Light Canopy Cover                     | 52. Water Container                     |
| 10. Side Panel                     | 32. Top Strip Inside Light Canopy          | 53. Compressor                          |
| 11. Fan Support                    | 33. Outline Border of Light Canopy         | 54. Condensor Fan                       |
| 12. Evaporating Fan                | 34. Low Strip Inside Light Canopy          | 55. Fixing Bracket for Dry Filter       |
| 13. Water Container                | 35. Foam Cabinet                           | 56. Up Baseboard                        |
| 14. Control Panel                  | 36. Top Frame of Light Canopy              | 57. Fan Support                         |
| 15. Fan Guard                      | 37. Left and Right Support of Light Canopy | 58. Lower Baseboard                     |
| 16. Lamp Stand                     | 38. LED Light Inside Light Canopy          | 59. Leveling Leg                        |
| 17. LED Light                      | 39. Bracket for LED Light                  | 60. Bumper Block                        |
| 18. Thermostat                     | 40. Top Hinge                              | 61. Compressor Guard                    |
| 19. Thermostat Panel               | 41. Low Frame of Light Canopy              |   |
| 20. LED Light Cover                | 42. Fixing Bracket for Grill               |   |
| 21. Light Switch                   | 43. Lower Hinge                            |   |
| 22. Shelf                          |  |   |

**SAFETY INSTRUCTIONS**

When using this appliance, always follow the basic safety precautions:

1. Read the entire User's Manual before operating this appliance.
2. Use this appliance only for its intended purpose as described in this User's Manual.
3. This cooler must be properly installed in accordance with the installation instructions before being used. See grounding instructions.
4. IDW requires that a dedicated circuit be used for the unit. Failure to do so voids warranty.
5. Never unplug your cooler by pulling on the power cord. Always grasp the plug firmly and pull it straight out from the outlet.
6. Unplug your cooler before cleaning or making any repairs.  
Note: If for any reason this product requires service, we strongly recommend that a certified technician perform the service.
7. When disconnecting the power source, wait at least 5 minutes to reconnect the power to avoid damage to the compressor and the cooling system.
8. Immediately repair or replace all electrical cords that have become frayed or otherwise damaged. Do not use a cord that shows cracks or abrasion damage along its length, the plug or the connector end.
9. Do not operate or store your cooler near or around explosive fumes, gasoline or other flammable vapors and liquids.
10. Do not use flammable liquids to clean unit.
11. Setting the temperature control to the 0 position does not remove power to the light circuit, perimeter heaters, or evaporator fans.
12. Do not adjust the temperature control. The temperature control is factory set between levels 4 and 5 for maximum performance.

**IMPORTANT!**  
Please Save These Instructions  
For Proper Disposal of the Refrigerator!

PRE-CAUTION, NON-OPERATING COOLERS SHOULD HAVE:

1. Door removed
2. Shelves kept in place in order to prevent any small child from climbing inside cooler

FOR PROPER DISPOSAL OF COOLER: Distributors / retailers need to contact a qualified service technician:

1. To recover all refrigerant from the cooler
2. To remove the compressor or remove the oil from the compressor

Then the distributor / retailer can contact their local metal recycling center to pick up the remaining cabinet, shelves, etc. By law, disposal of hazardous wastes may be subject to fines and imprisonment under the provisions of the environmental regulations. For more information please visit: <http://www.epa.gov/osw/hazard/index.htm>

**FEATURES**

- Designed with an elegant shape and quick refrigeration speed, this commercial-grade product is an ideal choice for shopping malls, supermarkets, hotels, etc.
- Transparent glass doors are built with hollow, toughened glass that provides a high level of heat insulation. Clear doors allow for high product visibility.
- The forced air system allows for fast cooling speeds, which helps maintain a consistent temperature.
- Adjustable shelves allow for a wide variety of products to be stocked.
- A built-in lock offers the ability to secure products.
- The refrigeration unit is designed for easy access, allowing for fast and simple repairs.
- This equipment is intended for storage and display of non-hazardous packaged product.

**INSTRUCTIONS**

**Ambient Environment**

- Place cooler on an even surface to reduce vibration and noise.
- To transport, do not tilt the cooler beyond a 45 degree angle.
- Do not place cooler in direct sunlight or near any heat sources.
- Do not place cooler in environment temperatures that exceed 109°F.
- Do not place cooler in below normal temperatures.
- Do not place cooler in extreme humid environments, this may cause components to rust.
- Do not place cooler near constant running or splattering water, this may cause immediate damage to refrigeration system.
- Must allow at least 2" between rear of cooler and wall for proper ventilation and heat dissipation of cooler.
- Do not place furniture or other articles with sharp edges near the cooler in order to prevent damage to the glass door.

**PREPARATION PRIOR TO OPERATION**

- Remove all packaging materials before using cooler. This includes: foam pedestal, adhesive tape (used to fix accessories) and protective gaskets.
- Inspect cooler for concealed damage. Immediately file a claim with the freight carrier if there is damage. IDW is not responsible for damage incurred during shipping.
- For proper operation, place the cooler on a dry, level surface.
- Clean the interior surface with a soft cloth and lukewarm water before operation.
- Keep cooler in an upright position for 30 minutes prior to use.
- IDW requires that a sole use circuit be dedicated for the unit. Failure to do so voids warranty.  
**WARNING:** Do not use extension cords.  
**WARNING:** Compressor warranties are void if compressor burns out due to low voltage.  
**WARNING:** Power supply cord should not be removed or altered in any way.

**Leveling**

- Set unit in its final location, making certain there is adequate ventilation in the room.  
**WARNING:** Warranty is void if ventilation is insufficient.
- Proper leveling of the GCG-26c cooler is critical to it operating correctly. Condensation removal and door operation will be affected by leveling.

< The cooler should be leveled front to back and side to side with a level.

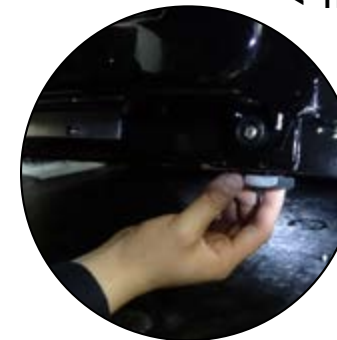

- Ensure that drain hose or hoses are positioned in the pan.
- Remove plug and cord from inside the lower rear of the cooler.
- The unit should be placed close enough to the electrical supply so that extension cords are never used.

**Shelving Installation** (Maximum load per shelf is 56 kg)

- Hook shelf clips on shelf strip.



- Position all four shelf clips equal in distance from the floor for flat shelves.



- Place shelf on shelf clips.



**REPLACING THE INTERIOR LIGHT**



**1** Press the plastic cover by the fingers and remove the plastic cover.

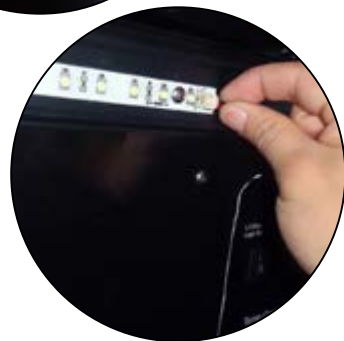

**2** Disconnect the lights.



**3** Unscrew (3) screws using a Phillip's screwdriver.



**4** Remove LED light strand.

**5** To install LED lights follow the above directions in reverse order.

**REPLACING THE DOOR LED LIGHTS**



**1** Unplug the cooler.



**2** Remove plastic cover.



**3** Disconnect top light strand.



**4** Disconnect middle light strand.



**5** Unscrew light strand.



**6** Remove entire light strand.

**7** To install LED lights follow the above instructions in reverse order.

Notes: If there are any malfunctions with the main control panel of LED lights, please contact a professional for replacement.

**REPLACING THE CANOPY LIGHT**

- 1 Unscrew the Graphics Holder on the Left Hand Side of the Top Canopy
- 2 Carefully slide out the entire Graphics piece.
- 3 Disconnect the lights.
- 4 Unscrew (3) screws using a Phillip's screwdriver.
- 5 Remove LED light strand.
- 6 To install LED lights follow the above directions in reverse order.

**STARTUP, OPERATION AND TEMPERATURE ADJUSTMENT**

**Operation**

- Prior to stocking cooler with product, it should be operated empty for half an hour.
- GCG-26c performance testing position of the thermostat is around 3.5-5.

**Temperature Adjustment  
Lit Door "Logo" Switch**



**Operation**

- The light switch located at the top inside of the cabinet on the right-hand side is the ON/OFF switch for the Lit logo located on the door of the cooler.

**REPAIR AND MAINTENANCE FOR REFRIGERATION DRAWER**

**\* A CERTIFIED TECHNICIAN IS REQUIRED TO REPAIR ALL REFRIGERATION COMPONENTS FOR WARRANTY PURPOSES.**

For convenient repair, the refrigeration components (compressor, evaporator, condenser, evaporation fan, condensation fan and filter) are designed using a split system; any component can be easily replaced. Replacement procedure is as follows:

- 1 Unplug the unit.
- 2 Remove the screws from the front grill, and then remove the grill.
- 3 Unplug all connections and terminals that are in need of repair.
- 4 Using a screwdriver, remove screws from refrigeration drawer.
- 5 Slide the Refrigeration Drawer out to easily access refrigeration components. Remove the component to replace or repair.
- 6 After repair, re-install all parts using the reverse procedure.

**CONDENSER MAINTENANCE**

It is essential to keep the condenser coils clean and free of dust and debris at all times. It is required to periodically clean the condenser coils with a soft bristle brush or vacuum-cleaner to properly maintain the refrigeration system. Failure to clean the condenser at regular intervals may cause failure of the refrigeration system and could void the warranty.

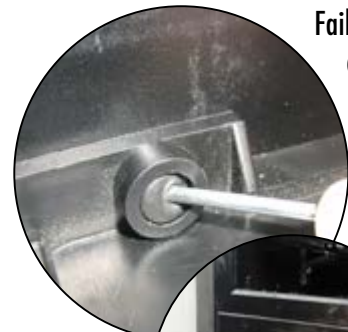

1 Remove the rubber cap from the front Grill.



2 Using a small Phillips head screwdriver, remove the three screws as shown.



3 The front plastic grill can now be removed by pulling it up.



4 Using plastic bristle brush, carefully clean the coil being aware that coils can bend or be damaged if too much force is used - shown left.

5 Replace grill and utilize the Phillips screwdriver to tighten the screws into place, replace the rubber caps.

**MAINTENANCE - Cleaning Shutdown Questions and Answers**

**Cleaning and Maintenance**

- 1 Unplug the cooler before cleaning.
- 2 Use a soft cloth or sponge with water or soap (non-corrosive mild detergent), while cleaning. After cleaning, wipe the cooler using dry cloth to keep the cooler from rusting.
- 3 Do not spray water on the cooler, and do not use hard or steel brushes to clean the cooler.
- 4 Do not use organic solvents, boiling water, washing powder or acid while cleaning.

If the cooler's power will be off for a long period of time, unplug it, clean as instructed above, and keep door open until dry.



**CANOPY GRAPHICS REPLACEMENT**



1 Unscrew the Graphics Holder on the Left Hand Side of the Top Canopy



2 Carefully slide out the entire Graphics piece.

3 Replace with a new Graphics piece.

4 Carefully insert and slide in the new Graphics piece.

5 Fix the Graphics Holder by fastening the screw.

**SETTING UP SPACER & POWER CORD HOLDERS**



The GCG-26c is supplied with one set (2 pieces) of Spacers to hold the extra length of Power Cord (shown in picture below)

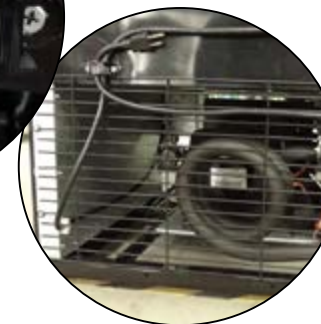

1 Take out the two Spacers and screws supplied in the Accessory Pack shipped with the Cooler.

2 Use a Philips screw driver to fix the two Spacers at positions as shown in picture below.

**SPECIFICATIONS**

MODEL	VOLUME (L)	RATED VOLTAGE	CLIMATE CLASS	RATED CURRENT	LAMP INPUT POWER	REFRIGERANT
GCG-26 GCG-26-C14N7 GCG-26-C14NG GCG-26-C14NI GCG-26-C14NM GCG-26-C14NJ	650	220-240V/50Hz	4 (30-55%)	2.7A	26W	R134a/270g
19W						
G-26 G-26-C14N7 G-26-C14NG G-26-C14NI G-26-C14NM G-26-C14NJ						

**Troubleshooting**

The following are not Malfunctions:

Issues	Solutions
Liquid flowing noise within cooler	This liquid is the sound of the cooling agent flowing through the pipes.
Refrigeration system is shutdown for longer periods of time while temperature inside is still very low.	This refrigerator has a strong level of heat preservation and can maintain a relatively ambient temperature.
Condensation on glass door	This may be due to a high indoor humidity or a low inside temperature value may be set. Wipe the door dry with a towel.

- 1 This refrigerator has been designed and manufactured according to National standards. If there are any questions during use, refer to this operation manual to help troubleshoot problems.
- 2 When disposing of the cooler, please remove the door and lock assembly to avoid children accidentally becoming trapped inside the cooler.

**After Sales Service**

Any product has the possibility of malfunction. Please observe the cooler's operation and any changes to product being stored. If there are any abnormal cases, refer to the table below. If there is still no change after following the below instructions, please inform our service center in a timely manner to avoid a further loss of the unit.

Issues	Solutions
Cooler is not functioning.	Please check power supply: <ul style="list-style-type: none"> <li>• Fuse damage</li> <li>• The plug is not securely inserted into the wall socket</li> <li>• Check for low voltage</li> </ul>
Cooler is not keeping product cool.	<ul style="list-style-type: none"> <li>• Provide ample space between all products to ensure proper circulation of air.</li> <li>• Keep unit away from direct sunlight or other heating source.</li> <li>• Keep door closed as often as possible.</li> <li>• Be certain cooler is not touching external objects or walls.</li> </ul>
Excessive noise	<ul style="list-style-type: none"> <li>• Be certain the cooler is placed on a level surface.</li> <li>• Be certain cooler is not touching external objects or walls.</li> </ul>

**GCG-26c CIRCUIT DIAGRAM**

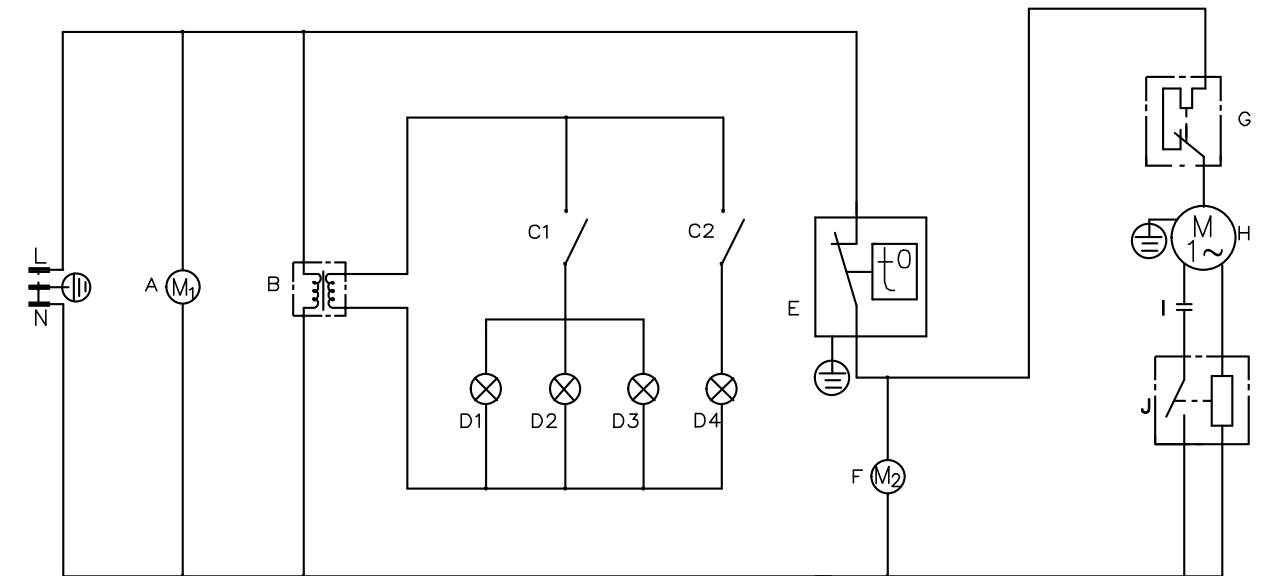

- A: Evaporator Fan
- B: Switching Power Supply for All Lights
- C1: On/Off Switch for Interior and Canopy Light
- C2: On/Off Switch for Lit Door Logo Light
- D1: Interior Top LED Light
- D2: Door Side LED Light
- D3: Canopy LED Light
- D4: Logo LED Light
- E: Thermostat
- F: Condenser Fan
- G: Overload for Compressor
- H: Compressor
- I: Compressor Starting Capacitor
- J: Compressor Relay



GCG-26c ELECTRICAL WIRING DIAGRAM

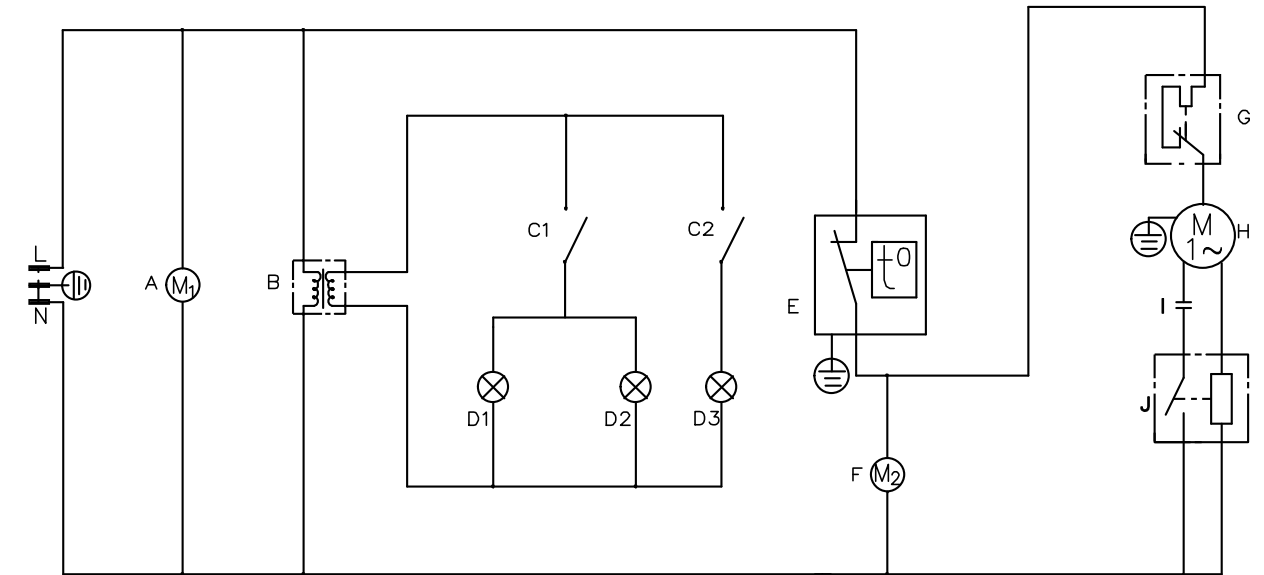
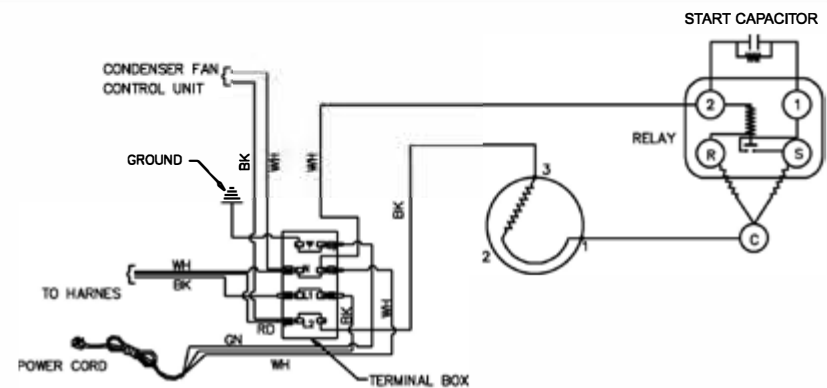
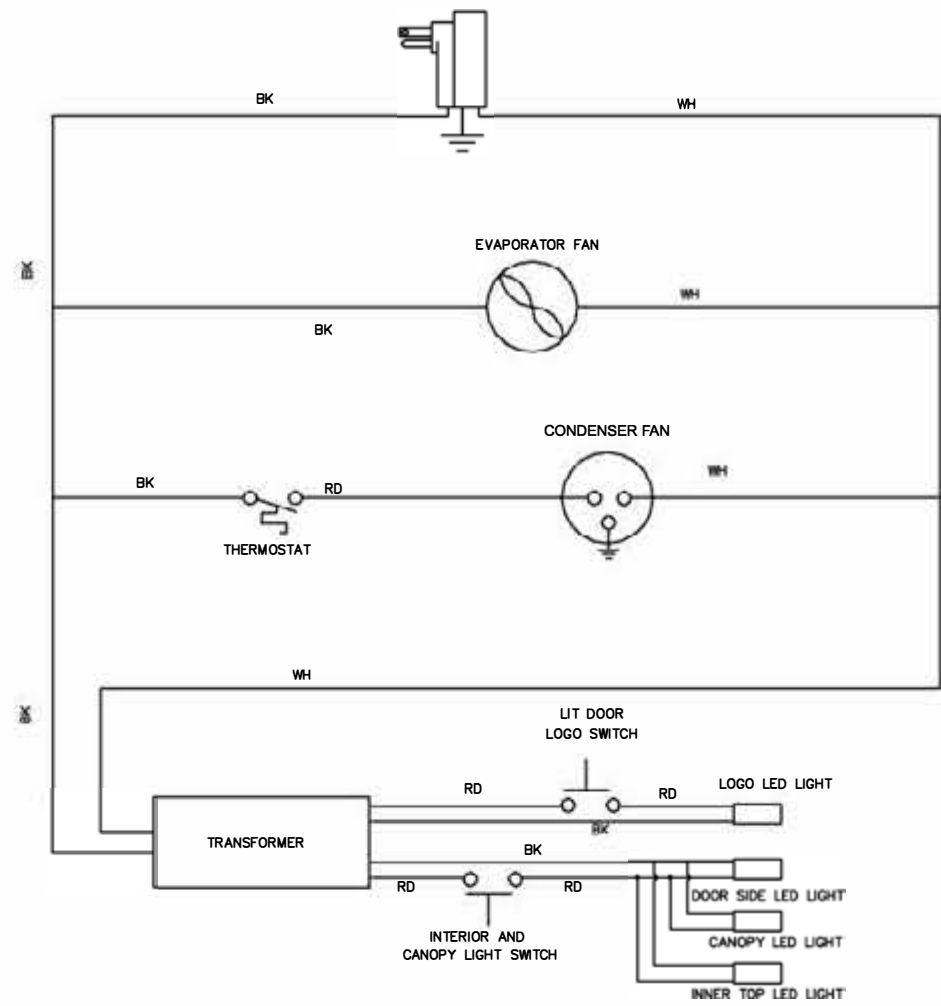

- A: Evaporator Fan
- B: Switching Power Supply for All Lights
- C1: On/Off Switch for Interior Light
- C2: On/Off Switch for Canopy Light
- D1: Interior Top LED Light
- D2: Door Side LED Light
- D3: Canopy LED Light

- E: Thermostat
- F: Condenser Fan
- G: Overload for Compressor
- H: Compressor
- I: Compressor Starting Capacitor
- J: Compressor Relay

G-26c ELECTRICAL WIRING DIAGRAM

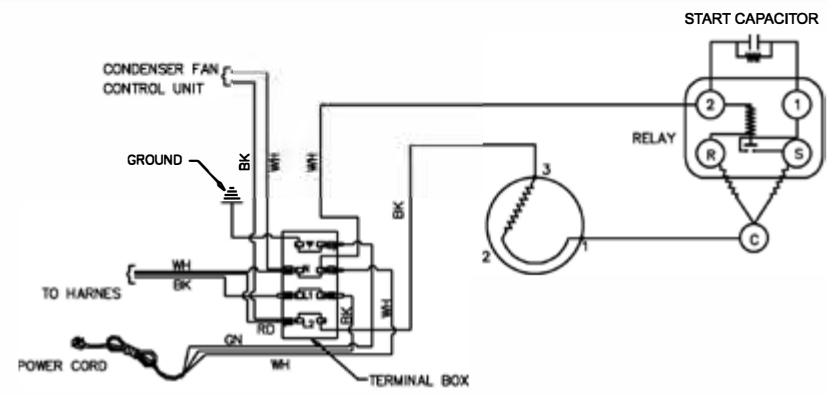
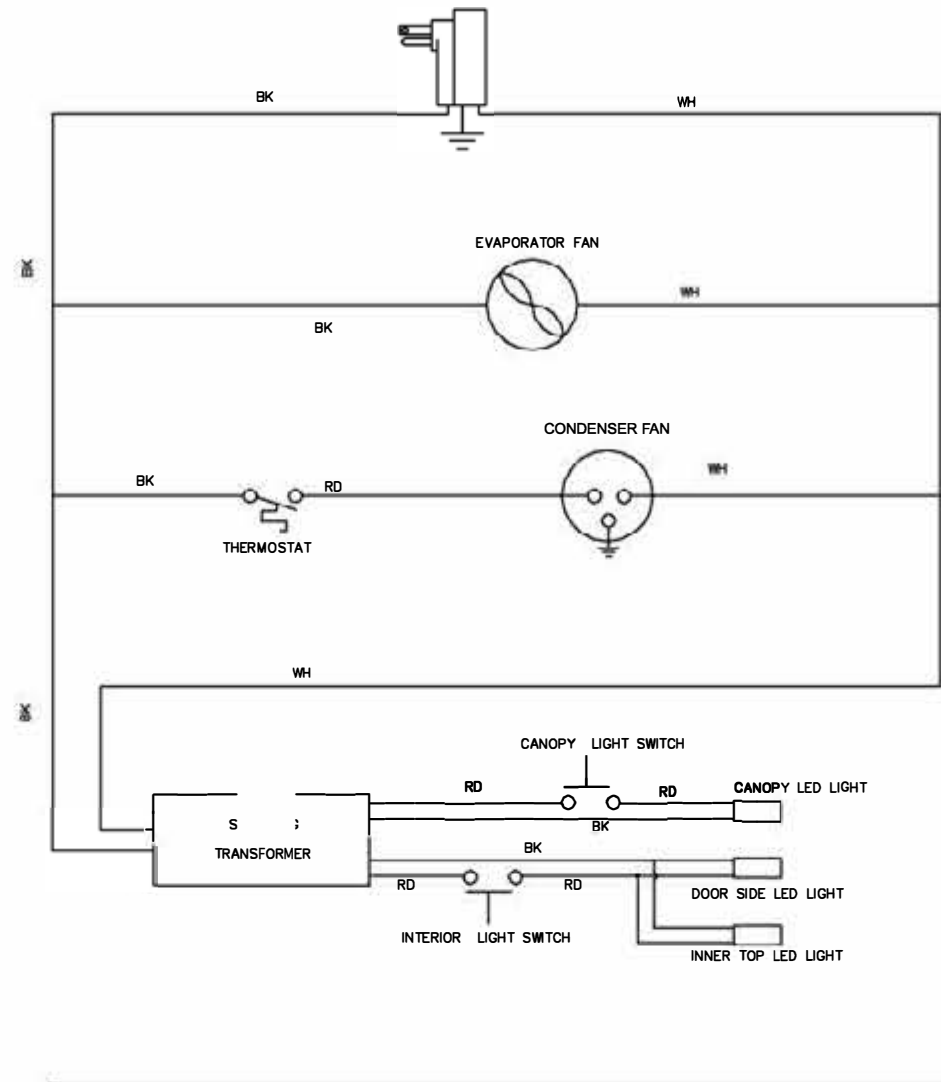



*Innovative DisplayWorks, Inc.*

To locate the distributor in your area go to: <http://www.idw.global/contact/#distributors>