

# G-6c

BEVERAGE COOLER



Instruction Manual

**G-6c**

## FOR YOUR FUTURE REFERENCE

- This easy-to-use manual will guide you in getting the best use of your cooler.
- Remember to record the model number and the serial number. This information can be found on the inside of your cooler.
- Keep your receipt with this manual for future warranty service.

Model #: \_\_\_\_\_

Serial #: \_\_\_\_\_

Date of Purchase: \_\_\_\_\_

## TABLE OF CONTENTS

Parts and Identification .....	2
Safety Instructions.....	3
Installation .....	3
Electric Connection .....	3
Start .....	3
Light Control .....	3
Maintenance .....	4
Cleaning .....	4
Condenser Maintenance .....	4
Light Replacement.....	4
Power Failure.....	4
Moving the cooler.....	4
Drip Pan .....	4
Troubleshooting .....	5
Refrigerant .....	5
Circuit Diagram.....	6

## PARTS & IDENTIFICATION

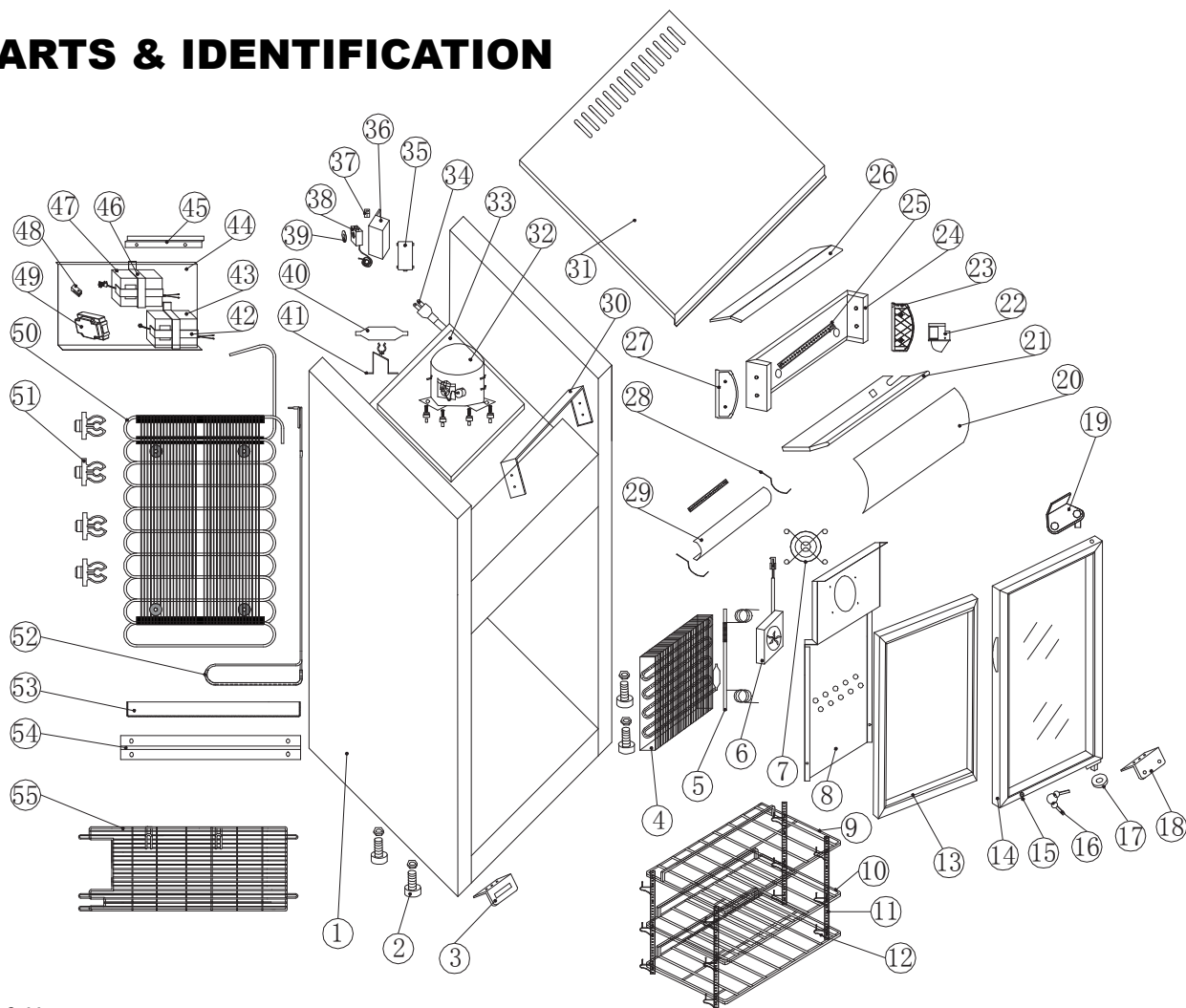

- |                         |                                     |                                 |
|-------------------------|-------------------------------------|---------------------------------|
| 1. Cabinet              | 20. Light Cover                     | 38. Thermostat                  |
| 2. Leveling Leg (4)     | 21. Lampshade Bottom Frame          | 39. Thermostat Label            |
| 3. Lockpin              | 22. Fan Switch                      | 40. Filter Drier                |
| 4. Evaporator           | 23. Canopy Left Side                | 41. Drier Bracket               |
| 5. Return Pipe          | 24. Fixation Board for Light        | 42. Thermostat Box Tray (Small) |
| 6. Evaporator Fan       | 25. LED Light (4)                   | 43. Evaporator Fan Transformer  |
| 7. Evaporator Fan Grill | 26. Lampshade Top Frame             | 44. Power Supply Board          |
| 8. Evaporator Plate     | 27. Canopy Right Side               | 45. Power Supply Board Bracket  |
| 9. Large Shelf          | 28. Fixation of Inner Lampshade (2) | 46. Transformer Box (Large)     |
| 10. Shelf (2)           | 29. Interior Light Bracket          | 47. Transformer                 |
| 11. Pilasters (4)       | 30. Top Board Bracket               | 48. Plastic Clip                |
| 12. Shelf Clips (12)    | 31. Cabinet Board                   | 49. Junction Box                |
| 13. Door Gasket         | 32. Compressor & Accessories        | 50. Condenser                   |
| 14. Glass Door          | 33. Compressor Base                 | 51. Condenser Bracket (4)       |
| 15. Lock                | 34. Power Cord                      | 52. Connecting Pipe             |
| 16. Key                 | 35. Thermostat Box Cover            | 53. Drip Pan                    |
| 17. Bottom Hinge Washer | 36. Thermostat Box                  | 54. Drip Pan Bracket            |
| 18. Bottom Hinge Board  | 37. Switch (2)                      | 55. Rear Grill                  |

**BEFORE USING, PLEASE READ ALL INSTRUCTIONS****SAFETY INSTRUCTIONS**

To reduce the risk of fire, electric shocks, or injury when using your cooler, please note the following basic precautions:

- Never clean appliance parts with flammable fluids.
- Do not store or use gasoline or any other flammable vapors and liquids in the vicinity of this or any other appliance. The fumes can cause a fire or explosion.
- As with all electrical appliances, please consult a licensed repair technician for any repairs.

**INSTALLATION**

- Keep cooler in an upright position for 1-hour prior to use. This is essential for proper operation. If the cooler is transported in the horizontal position, the cooler must be returned to the upright position and not plugged in for 1 hour.
- Remove all the packing material before using your cooler.
- Clean the interior surface with a soft cloth and lukewarm water.
- If the cooler is transported in the horizontal position, check the drain pan and ensure that it is properly positioned above the compressor.
- For proper operation, place the cooler on a dry, level surface.
- Place the cooler at least 4" away from any walls. Otherwise, this could cause damage to the electrical cord and block the air circulation to the appliance.
- Do not block the air intake that ventilates the condenser unit.

**ELECTRIC CONNECTION**

- This model operates with an 115V/60Hz power supply. Check the electrical outlet for proper voltage.
- Warning: Plug unit directly into wall outlet. Do not use an extension cord or any other multiple connectors. Do not use an extension cord or any other multiple connectors, this could cause compressor failure.
- For your safety, plug the unit into a grounded wall outlet.

**START**

- Plug the cooler into the electrical outlet. For optimum performance, run cooler for 3 hours prior to use.
- Temperature Control: Do not adjust the temperature control. The temperature control is factory set to provide maximum performance. If really necessary, you can turn the thermostat by screw driver clockwise to have lower temperature inside the cooler

**LIGHT CONTROL**

- The inside light is controlled by the magnetic switch.

## MAINTENANCE

### Cleaning

- Before cleaning the appliance, always remember to unplug it.
- Unplug the cooler at the electrical outlet; never pull the service cord.
- Do not use sharp or pointed objects for cleaning.
- Clean the inside cabinet of the cooler with a clean damp cloth or with neutral soap. Avoid damage by using non-abrasive or flammable cleaning products.
- Clean the condenser at least once a month with a vacuum cleaner or a brush to eliminate the dust accumulation.

### Light Replacement

- Unplug the cooler before removing the bulb.
- Remove the screws.
- Remove the light cover gently.
- Take out the old bulb.
- Replace the used bulb with new equivalent fluorescent bulb.
- Install the light cover and tighten the screws.
- Plug in the cooler.

### Power Failure

- Please minimize the frequency of opening the door during a power failure.
- If your cooler is unused for an extended period of time, unplug, empty, and clean your cooler and keep the door open to avoid condensation, formation of molds, or odors.

### Moving The Cooler

- Empty the unit.
- Secure all loose parts inside the cooler.
- Tape the door shut.
- During transportation, make sure that the cooler is in an upright position.

### Drip pan

- During normal compressor cycle, water will drain into the drain pan and evaporate.
- To clean, gently pull the drain pan towards you and remove. Slowly reinstall it after cleaning.

## TROUBLESHOOTING

If your cooler is not working properly:

- Check the electrical outlet for power, and that the plug is properly inserted.
- Check to see if the circuit breaker is tripped or the fuse is blown.
- Check the condenser for proper cleaning.

If your cooler is making noise:

- Check that the cooler is level and on a flat surface.

If the compressor turns on and off frequently:

- The room temperature is higher than normal.
- The door is not closed completely.
- The door gasket is not sealed well.
- There is insufficient clearance around the cooler.
- The temperature is not set properly.
- The cycling frequency will reduce when all of the cans reach the set temperature.

The following is not a malfunction:

- It is normal to hear gurgling sounds caused by the flow of refrigerant when each cooling cycle ends.

## REFRIGERANT

- The G-6c cooler utilizes R134a refrigerant.

## SPECIFICATIONS

Model:	G-6c Beverage Cooler
Power Supply (V/Hz):	110V/60Hz
Dimension (W x D x H):	22.25" x 21.5" x 36.25"
Box Dimension (W x D x H):	25.5" x 232" x 38.25"
Maximum Load Per Shelf:	55 lbs.
NSF-7 Standard:	This equipment is intended for the storage and display of non-potentially hazardous bottled or canned products only.

## CIRCUIT DIAGRAM

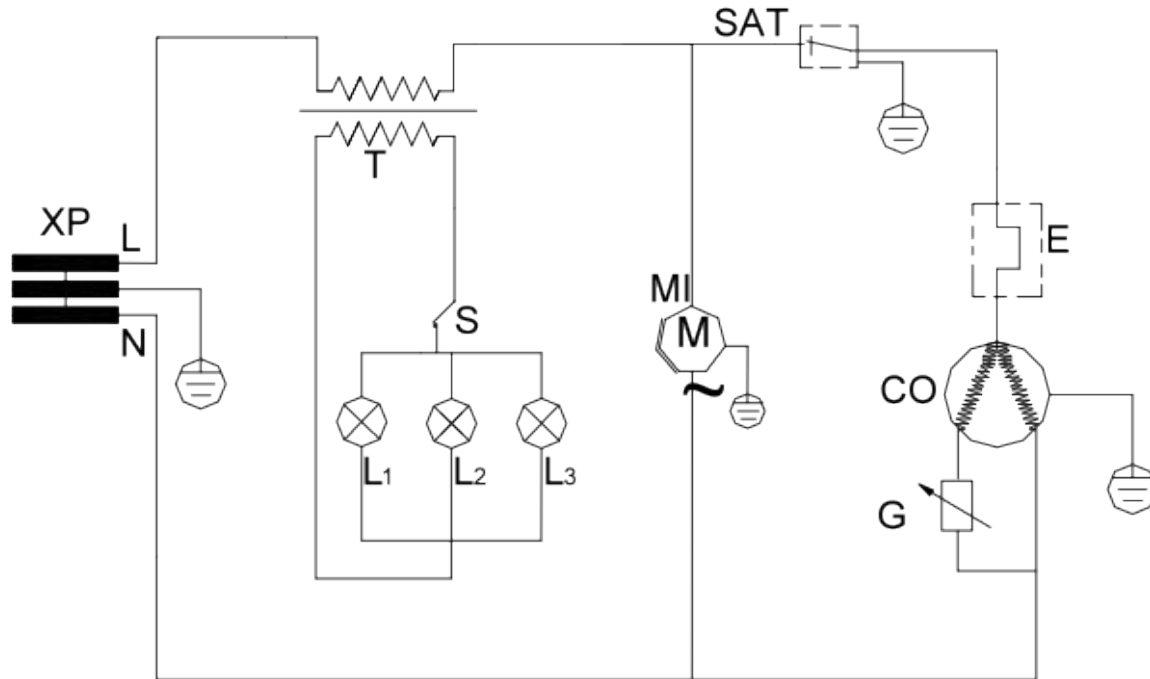

- XP-Plug
- G-Startup
- Co-Compressor
- T-Adaptor
- S-LED Lamp Switch
- L1,L2,L3-LED Lamp
- MI-Evaporator motor fan
- SAT-Temperature control
- E-Outstanding safeguard







*Innovative DisplayWorks, Inc.*

To locate the distributor in your area go to: <http://www.idw-usa.com/contact#distributors>